



OPERATOR'S MANUAL

IMPORTANT!
Safety Instructions

All Operators Must Read These Instructions Before Use

Any electrical appliance can be dangerous if used incorrectly. Some of the safety precautions given in this manual apply generally to many appliances. Other warnings are specific to the use of this snow thrower.

General Safety WARNINGS!

You and any other operator of this snow thrower must read, understand and follow these instructions in their entirety, and should re-read them at the start of each snow season. Failure to follow any instruction may result in **BODILY INJURY** (including electric shock) or possible **FIRE**.

Notice the personal safety alert symbol used in this manual to draw your attention to a WARNING given along with the particular operating instruction. This means that an operation requires special ATTENTION, CAUTION, and AWARENESS.

1. **Keep children, pets, and others away from the work area:** Be aware that the normal noise of the machine when turned on may make it difficult for you to hear approaching people.
2. **Use the electric cord and extension cord safely:**
 - A. Keep cord away from heat sources and sharp objects.
 - B. Prevent oil or other fluids from spilling onto snow thrower or cord.
 - C. Never carry the snow thrower by cord or yank it to disconnect from electrical outlet. Keep cord away from heat, oil, and sharp edges.
 - D. Replace or properly repair damaged cords. If cord is damaged in any manner while plugged in, pull extension cord from wall receptacle.
 - E. Extension Cord: **WARNING** – Only use a UL rated extension cord for **OUTDOOR**, all-weather use (usually orange color). To prevent the disconnection of the snow thrower from the extension cord during operation, make a knot as shown on page 5; see **WARNING** box on page 5 for more cord information.
3. **Wear proper clothing:** Wearing rubber boots offers additional protection from electric shock when operating this snow thrower. Do not wear loose clothing that may become caught in the machine.
4. **Moving parts present risks:** Keep hands away from moving parts. Guards must be properly placed to protect operator. Shut off and disconnect cord before touching

any parts other than the handles and switch.

5. **Hand-held operating position:** Operating this snow thrower in the hand held position is unsafe.
6. **Surfaces:** This snow thrower is intended for use on paved surfaces. The unit should not be used on gravel or stone surfaces.
7. **Unintentional operation:** Do not carry plugged-in snow thrower with finger on switch. Be sure that the switch is off when plugging in.
8. **Body position:** Be aware of your footing and body positioning to maintain proper balance at all times; watch for uneven surfaces and don't overreach.
9. **Excessive force:** The snow thrower was designed to respond at a certain rate for various snow conditions for optimum safety and performance. Don't force it; keep pressure constant.
10. **Hitting an object:** If the snow thrower accidentally strikes an object, first stop; remove key then plug. Inspect for damage; repair or replace part before using the snow thrower again.
11. **When work is completed:** Disconnect from the power source when not in use, when changing accessories, and before performing any maintenance function.
12. **Store safely:** Store indoors in a dry area between uses. Store in a locked area, where children and unauthorized people cannot gain access.
13. **Maintain for safety and longevity:** See instructions in this operator's manual for proper maintenance. Use only those replacement parts made for your model.
14. The use of any other accessory or attachment might increase the risk of injury.

Save These Instructions

Assembly

CAUTION

Inspect wiring, which, if damaged during shipping, may cause serious bodily injury during equipment use. If any damage is seen or suspected, do not assemble. Instead, contact Snow Joe customer service (1-866-SNOWJOE) for assistance.

Handle with care during assembly so that electrical wiring does not become damaged.

Upper and Lower Tube Assembly

1. To secure parts during shipping, a wire is wrapped around the upper and lower tube sections. Remove it, but don't discard (Figure 1).

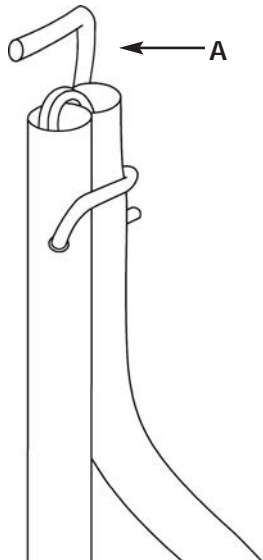

Figure 1

A. Shipping wire

2. Slide the lower tube (B) into the upper tube (A) (Figure 2).

Note: Before you connect the tubes, you may find it easier to remove the slack in the wire. Slightly pull the wire from the bottom of the lower tube (B) before you join the tubes together.

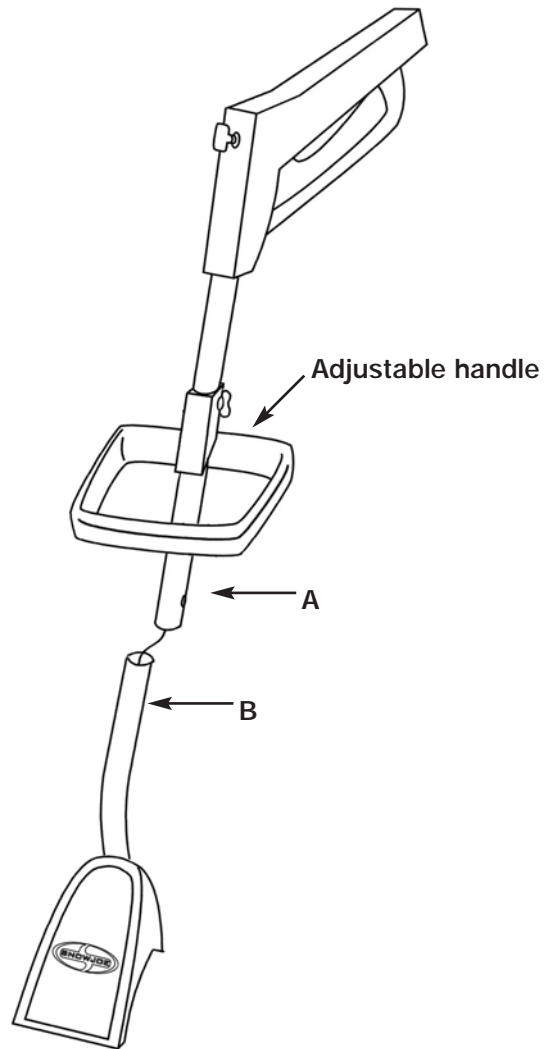

Figure 2

A. Upper tube
B. Lower tube

3. After sliding lower tube (B) inside the upper tube (A), line up the screw holes on each tube (Figure 3).

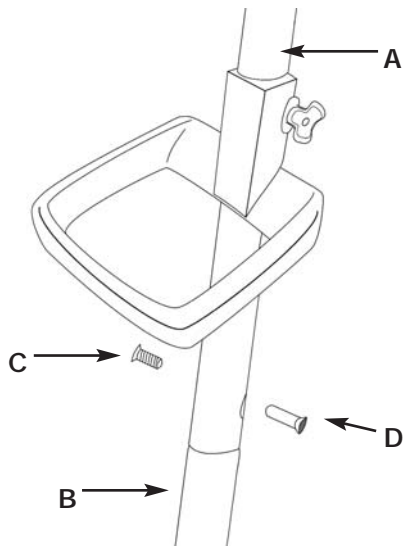

Figure 3

- | | |
|---------------|--------------------|
| A. Upper tube | C. Slotted screw |
| B. Lower tube | D. Countersunk nut |

4. Locate in the Parts Bag the slotted screw (C) and the countersunk nut (D). Insert the screw through the aligned holes in the upper and lower tubes and secure other end with the nut.

Note: You may have to carefully move the wiring inside the tube to one side if it blocks the path of the screw. (Use the shipping wire provided; do not use a sharp tool.)

5. Loosen the adjustable handle and reposition until it reaches the optimum length for the principal operator, then retighten the bolt in Figure 4. (Readjust for each subsequent operator.)

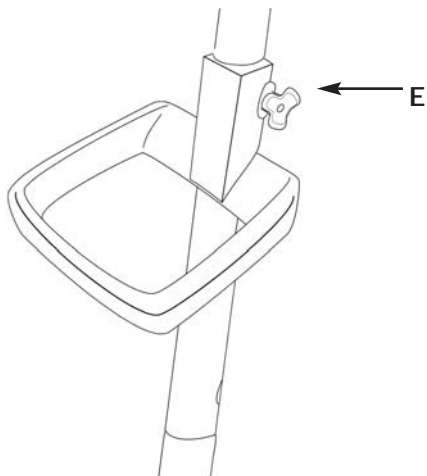
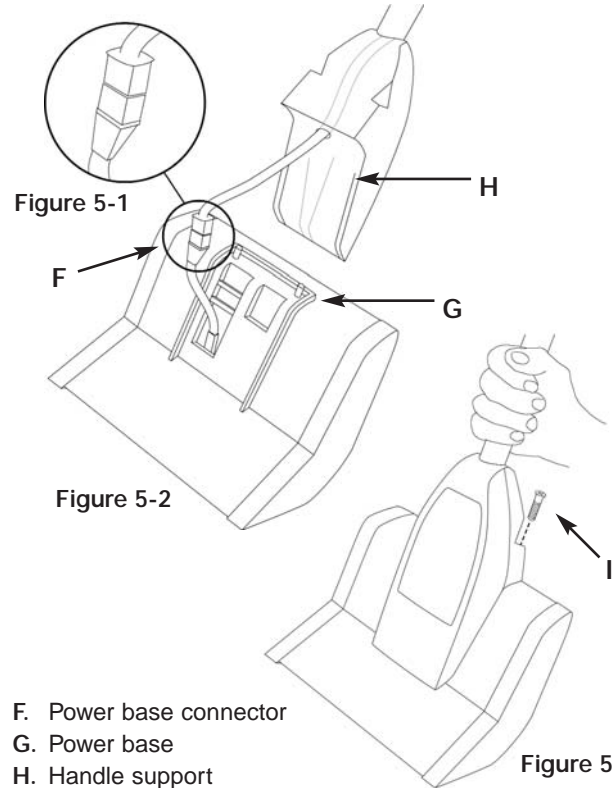

Figure 4

- E. Carriage Bolt

Power Base Assembly

1. Position the power base (G) beneath the handle support (H) as shown in Figure 5-2.



- F. Power base connector
G. Power base
H. Handle support
I. 2 Phillips-head screws

2. Pull the power base connector (F) out of the power base (G). Push to snap together the connector on the handle support to the power head's connector; only one position is possible, and they should fit without forcing (Figure 5-1).
3. Push the coupled connectors back into the motor compartment.
4. With the Snow Joe decal on the handle support (H) facing you, line up the grooves in the handle support (H) with the grooves in the power base, and slide together until interlocked (Figure 5-3).
IMPORTANT: If you encounter any resistance, **STOP!** Possibly the wiring and connectors are out of position; in that case, reinsert them with care into the motor compartment and repeat step 4.
5. Locate two Phillips-head screws (I) in the Parts Bag. Insert the first screw into the hole in back of the handle support and turn until tight. Insert the second screw into second hole and tighten (Figure 5-3).

Operation

NOTE: It is best to remove snow before it becomes packed down.

WARNING

Electric shock may cause **SEVERE INJURY** or **DEATH**. Heed these warnings:

- Do not allow any part of snow thrower to make contact with water while powered on. If the appliance becomes wet while turned off, wipe dry before starting.
- Use only a UL-rated extension cord for outdoor, all-weather use. Do not use an extension cord over 150 feet (46 meters).
- Don't touch the appliance or its plug with wet hands. Don't stand in water; wearing rubber boots offers some protection.

EXTENSION CORD CHART

| | | |
|-----------------|----------------|---------------|
| Cord length is: | 100 ft. (30 m) | 150 ft. (46m) |
| Wire gauge is: | 16 | 14 |

1. **Extension cord:** Note that the snow thrower has a polarized plug (J), with one prong slightly longer and wider than the other. The extension cord plug and the slotted end should be likewise polarized, so that the original plug fits snugly into the extension cord slots.

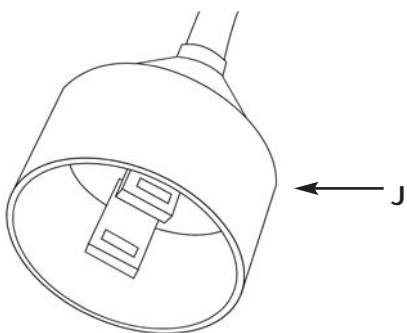

Figure 6

J. Polarized plug

To prevent the snow thrower cord and extension cord from disconnecting during use, tie the extension cord into a loose knot around the lower bar (K) of the handle as shown in next step (Figure 7, Item O).

2. Plug the extension cord into a wall outlet. Insert the key (L) into the slot in front of the hand-grip (M) (Figure 7).

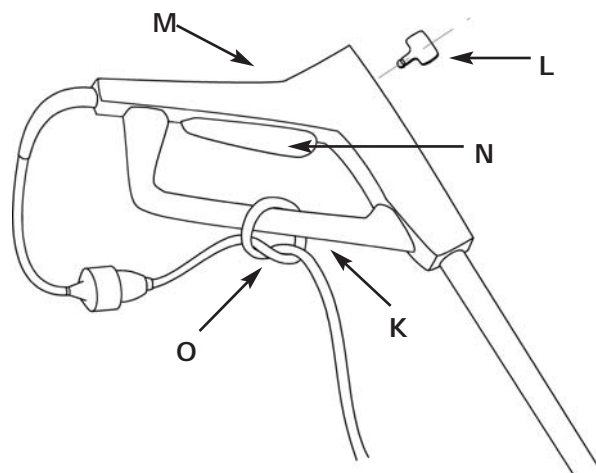

Figure 7

- K. Lower bar
- L. Key
- M. Hand-grip (Top bar)
- N. On/Off switch (under hand-grip)
- O. Cord tied to handle

Powering On and Off

3. Insert the key (L). Squeeze the On/Off switch (N), as shown in Figure 7. Release the switch by releasing grip pressure.
4. When finished with work, remove the key and disconnect the extension cord.

Operating Procedures

1. **Turn on the snow thrower switch:** With key inserted, squeeze on/off switch to power on. Position the appliance so that the blade makes level contact with the ground, by titling it slightly forward (away from you). When starting in deep snow, see suggestion below.
2. **Begin to push the snow thrower forward:** Do not rush. If the snow is being completely cleared from the ground, you are moving at the correct rate of forward motion.
3. **Snow depth:** Your rate of speed will depend on the depth of the snow.
 - The snow thrower's capacity for snow removal is 4 inches (10 cm) for each pass. A single pass should clear all snow up to that depth, permitting you to move at a steady rate on a straight path.
 - For snow deeper than 4 inches, a side-to-side motion is effective. Hold in each hand the top and lower handles and make a sweeping pass from side to side; you should aim to remove 4 inches with each sweep. Keep up a steady back and forth movement for each area of work. Rest at intervals as needed.
4. **Desired path width:** You can only clear a path as wide as the appliance width at one time. By angling the snow thrower to the right or to the left of your current path, place the cleared snow wherever you desire it to go. Of course, you should place it where it does not need to be cleared later.
5. **Note wind direction:** If possible, move in the same direction as the wind.
6. **Working on gravel or pebbles:** To avoid throwing loose surface material along with snow, push down on the handle to raise the scraper above the gravel or pebbles.
7. **Power cord and extension cord:** Inspect both cords at the end of each snow-clearing session to detect any damage; if damaged, replace. Be careful to avoid the blade running over the cord. Keep cords clear of heat sources, sharp objects, or heavy weights standing on them when in storage. Don't yank on cords or otherwise abuse them.

Maintenance

WARNING

Risk of Serious Bodily Injury:

Remove the key and disconnect the extension cord before beginning any maintenance task. If the switch were to engage accidentally serious injury could result.

Lifetime Lubrication

Lubrication is not necessary and may damage the appliance. The snow thrower is lubricated for lifetime use at the factory before shipment.

Replacing the Rotor

1. Remove lock nut (counterclockwise) and flat washer (Figure 8).

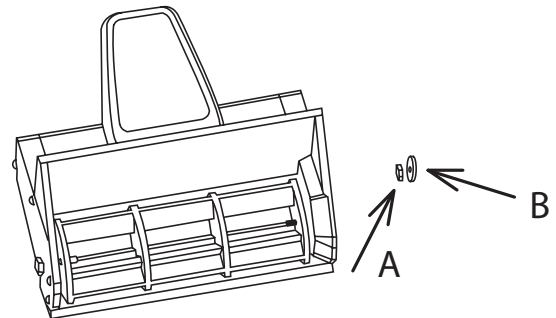

Figure 8

- A. Lock nut
- B. Flat washer



A Two-Year Full Warranty for residential use in the United States and Canada

General Conditions: Snow Joe®, LLC warrants this product to the original purchaser for two years against defects in material or workmanship when used for normal residential purposes. In order to obtain a replacement unit or repair the existing unit, you must return the complete unit, postage prepaid, to the place of purchase, or to the Snow Joe Center, (61 Executive Avenue, Edison, NJ 08817).

This warranty is intended to cover product defects only. Snow Joe, LLC is not liable for indirect, incidental or consequential damages in connection with the use of the Snow Joe products covered by this warranty. This warranty does not cover any cost or expense incurred by the purchaser in providing substitute equipment or service during reasonable periods of malfunction or non-use of this product, while waiting for completion of repairs under this warranty. Some states do not allow exclusions of incidental or consequential damages, so the above exclusions may not apply in all states. This warranty gives you specific legal rights in your state, which vary from state to state.

If you wish to contact Snow Joe, please direct inquiries to the:
Customer Service Department
Snow Joe Center
61 Executive Avenue
Edison, NJ 08817

Customers who have purchased Snow Joe products exported from the United States and Canada should contact their Snow Joe Distributor (Dealer) to obtain information applicable for your country, province, or state. If for any reason, you are not satisfied with the distributor's service, or if you have difficulty obtaining warranty information, contact your Snow Joe importer. If in the event your efforts are unsatisfactory, please write to the Snow Joe Center at the above address.