



OPERATOR S MANUAL

IMPORTANT!

Safety Instructions

All Operators Must Read These Instructions Before Use

Any electrical appliance can be dangerous if used incorrectly. Some of the safety precautions given in this manual apply generally to many appliances. Other warnings are specific to the use of this snow thrower. Keep this manual for future reference.

General Safety WARNINGS!

You and any other operator of this snow thrower must read, understand and follow these instructions in their entirety, and should reread them at the start of each snow season. Failure to follow these instructions may result in ELECTRIC SHOCK, FIRE and/or serious PERSONAL INJURY.

Notice the personal safety alert symbol Δ used in this manual to draw your attention to a WARNING given along with the particular operating instruction. This means that the operation requires special ATTENTION, CAUTION, and AWARENESS.

1. Work Area

- a. **Keep work area clean and well lit.** Cluttered, dark areas invite accidents.
- b. **Do not operate snow thrower in an explosive atmosphere,** such as in the presence of flammable liquids, gases, or dust. Electrical appliances create sparks that may ignite the dust or fumes.
- c. **Keep children, pets, and bystanders away from work area.** Be aware that the normal noise of the machine when turned on may make it difficult for you to hear approaching people.

2. Electrical Safety

- a. **Electrical plugs must match the outlet.** Never modify the plug in any way. Do not use any adapter plugs with grounded appliances. Unmodified plugs and matching outlets will reduce risk of electric shock.
- b. **Avoid body contact with earthed or grounded surfaces** such as pipes, radiators, ranges, and refrigerators. There is an increased risk of electric shock if your body is earthed or grounded.
- c. **Do not abuse the cord.** Keep cord away from heat, oil, sharp edges or moving parts. Damaged or entangled cords increase the risk of electric shock. Never carry the snow thrower by its cord or yank the cord to disconnect it from the electrical outlet.
- d. **Replace or properly repair damaged cords.** If

cord is damaged in any manner while plugged in, pull the extension cord from the wall receptacle.

- e. **Contact with water while operating the snow thrower can result in electric shock and serious bodily injury.** Do not use the snow thrower in damp or wet locations or expose to rain. Do not handle the plug or the appliance with wet hands or while standing in water.
- f. **Extension Cord - WARNING - Only use a UL rated extension cord for OUTDOOR, all-weather use (usually orange color).** To prevent the extension cord from disconnecting during operation, tie it around the top right side of the middle frame before connecting it to the snow thrower as shown in Figure 18. See WARNING box on page 10 for more cord information.
- g. **Turn off the power switch and disconnect the power cable before inspecting, servicing, repairing, or cleaning the snow thrower.** Any such operation should be performed after revolving parts inside the snow thrower stop completely.
- h. **Do not move or transport the snow thrower when the plug is connected to the power socket and the switch is turned on.**

3. Personal Safety

- a. **Stay alert** - Watch what you are doing and use common sense when operating the snow thrower. Do not use the machine when tired, ill, or under the influence of drugs, alcohol, or medication. A moment of inattention may result in serious personal injury.
- b. **Wear proper clothing** - Wearing rubber boots offers additional protection from electric shock. Do not wear loose clothing or jewelry that may become caught in the machine. Wear protective headgear to keep hair away from revolving parts of the machine. Safety glasses offer better protection than everyday eyeglasses.
- c. **Moving parts present risks** - Keep your face, hair, clothing, hands and feet away from moving parts. All guards and safety attachments must be installed properly before using the unit. Shut off and disconnect cord before touching any parts other than the handles and switch.
- d. **Surfaces** - This snow thrower is intended for use on paved surfaces. Do not use on gravel, stone, or other unpaved surfaces unless the snow thrower is adjusted for such surfaces according to the instructions given in the operator's manual.
- e. **Avoid accidental starting** - Make sure the switch is in the off position before plugging in the unit. Do not carry the snow thrower with your finger on the switch.

- f. **Body position** - Maintain proper footing and balance at all times. Place heels firmly on the ground and tightly grasp the handle bar. Watch for uneven surfaces and do not overreach. In case you fall or collide with the snow thrower, inspect the unit for damage. When stepping backwards, be careful to avoid obstacles beneath your feet or behind you to avoid falling.

4. Snow Thrower Use and Care

- a. **Know your snow thrower** - Familiarize yourself with the main parts of your snow thrower (Fig. 1).

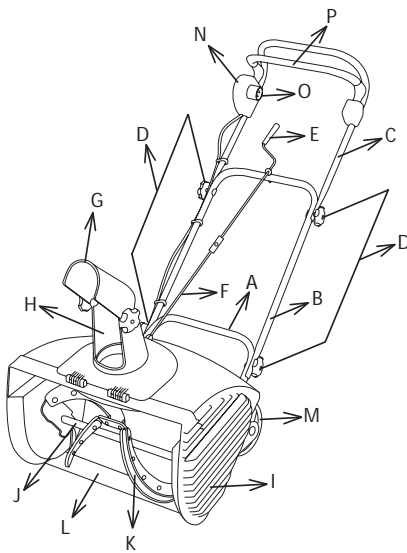

Figure 1

A-Lower frame	I-Main cover
B-Middle frame	J-Auger
C-Upper frame	K-Rubber plate
D-Joint fixing T-bolt and knob	L-Scraper
E-Upper chute crank	M-Pivot wheels
F-Lower chute crank	N-Switch housing
G-Chute deflector	O-Polarized plug
H-Discharge chute	P-Handle bar

Read the operator's manual carefully. Learn your snow thrower's applications and limitations as well as the specific potential hazards related to this machine. Do not use this machine for any purpose other than the one for which it was designed. Otherwise, it may cause mechanical defaults, serious damage or personal injury.

- b. **Preliminary unit inspection** - Thoroughly inspect the unit before use. Make sure all the parts are secure and installed correctly. If you notice any abnormalities, do

not use the machine until it has been properly repaired. Always perform a test run the first time you use the snow thrower or after replacing parts to ensure that the unit is functioning properly.

- c. **Preliminary area inspection** - Clear the area to be plowed before each use. Remove all objects such as rocks, broken glass, nails, wire, or string, which can be thrown by or become entangled in the snow thrower. Keep the area of operation clear of all persons, particularly children and pets.
- d. **Excessive force** - The snow thrower was designed to respond at a certain rate for various snow conditions for optimum safety and performance. Do not force it; keep pressure constant.
- e. **Malfunctioning switch** - Do not use the snow thrower if the switch does not turn it on and off. Any electrical appliance that cannot be controlled by the switch is not safe to use and must be repaired.
- f. **Hitting an object** - If the snow thrower accidentally strikes an object, first stop the snow thrower; inspect for damage; repair or replace any damaged part before restarting and operating the snow thrower.
- g. **Discharge chute safety** - Never direct the snow discharge chute at the operator, at bystanders, at vehicles or at windows. The throwing snow and foreign objects accidentally picked up by the snow thrower can cause serious damage and personal injury. Do not use your hands to unclog the discharge chute. Stop the motor before removing debris.
- h. **Hand-held operating position** - Operation of the snow thrower in the hand-held position is unsafe.
- i. **Abnormal operation** - If you notice the snow thrower running in an unstable state or hear abnormal sounds from the engine, stop the machine, disconnect the power immediately, and contact your original distributor.
- j. **Noise control** - When using the snow thrower, you must respect local laws and regulations regarding noise control and environmental protection. To avoid noise disturbance, you should carefully decide upon an appropriate operation time and consider the surrounding conditions.
- k. **When work is completed** - Disconnect the snow thrower from the power source when not in use, when changing accessories, and before performing any maintenance function.
- l. **Store safely** - Store snow thrower indoors in a dry area between uses. Keep in a locked area, where children and unauthorized users cannot gain access. Do not store the machine while it is still connected to the power source. It may cause damage and injury.
- m. **Maintain for safety and longevity** - Check for

misalignment or binding of moving parts, breakage of parts, and any other conditions that may affect the unit's operation. If damaged, repair or replace the damaged part before use. Use only those replacement parts made for your model. When replacing any parts, you must strictly observe the instructions and procedures described in this manual. Special care should be paid to any rubber parts, since these parts may increase the engine load and decrease its mechanical power if damaged.

Safety and Instruction Decals



Safety decals and instructions are easily visible to the operator and are located near areas of potential danger. Lost or damaged decals should be replaced.

TO START Press Switch Squeeze Bar	TO STOP Release Bar
PARA PONER EN MARCHA Presione el botón del interruptor Exprima la barra de la manija	PARA APAGAR Suelte la barra
POUR DÉMARRER Appuyez sur l'interrupteur Serrez la poignée	POUR ARRÊTER Relâchez la poignée

SJ 622U-2134



SJ 622U-2137

WARNING ! Electric shock can cause serious injury or death. To avoid electric shock: DO NOT USE SNOW THROWER IF WIRE INSULATION IS DAMAGED. READ ASSEMBLY INSTRUCTIONS AND OPERATOR S MANUAL.	ADVERTENCIA! Una descarga eléctrica puede causar lesiones graves o la muerte. Para evitarla: NO UTILIZAR EL LANZADOR DE NIEVE SI EL AISLANTE DEL CABLE EST DA ADO. LEER LAS INSTRUCCIONES DE ENSAMBLAJE Y EL MANUAL DEL OPERARIO.	AVERTISSEMENT ! Un choc électrique peut provoquer des blessures graves voire mortelles. Pour éviter les chocs électriques : N'UTILISEZ PAS LA SOUFFLEUSE À NEIGE SI L'ISOLATION D'UN FIL EST ENDOMMAGÉE. LISEZ LES INSTRUCTIONS DE MONTAGE ET LE MANUEL DE L'UTILISATEUR.
--	--	--

SJ 622U-2135

<p>⚠ D A N G E R</p> <p>DANGER Do not use hands to unclog chute. Stop motor before removing debris. Do not walk in front of running machine. Do not direct discharge at bystander. CAUTION Use for snow removal only. WARNING To reduce the risk of electric shock, replace damaged cord immediately. PELIGRO No emplee las manos para desatascar la tolva. Pare el motor antes de sacar el material atascado. No camine delante de la máquina en funcionamiento. No descargue directamente sobre los transeúntes. ADVERTENCIA De uso exclusivo para remover la nieve. ADVERTENCIA Para prevenir el riesgo de una descarga eléctrica, cambie el cable dañado inmediatamente. DANGER Ne pas déboucher le conduit d'éjection à la main. Arrêter le moteur avant d'ôter tout débris. Ne pas se mettre devant une machine en marche. Ne pas diriger le jet d'éjection de neige vers quelqu'un. ATTENTION N'utiliser que pour ôter la neige. AVERTISSEMENT Afin de prévenir le risque d'électrocution, remplacer immédiatement le cordon électrique abîmé.</p>	<p>DOUBLE INSULATED: When servicing, use only identical replacement parts. DOBLE AISLAMIENTO: Al darle servicio, use solo piezas idénticas. DOUBLE ISOLATION: lors de l'entretien, n'employer que des pièces de rechange identiques.</p> <p>Read operator's manual for operating and safety instructions. Replacement manual available by sending model and serial numbers to: Snow Joe, LLC, 61 Executive Avenue, Edison, NJ 08817, or visit www.snowjoe.com</p> <p>Lea el manual de instrucciones de seguridad y operación. Tenemos disponible manuales de reemplazo si envía el número de modelo y número de serie a: Snow Joe, LLC, 61 Executive Avenue, Edison, NJ 08817, o visite www.snowjoe.com</p> <p>Lire le manuel pour connaître le mode d'emploi et les prescriptions de sécurité. Manuel de rechange disponible sur envoi du numéro de modèle et du numéro de série à : Snow Joe, LLC, 61 Executive Avenue, Edison, NJ 08817, ou visiter le site www.snowjoe.com</p> <p>SNOW JOE ULTRA MODEL 622U 120 VAC 60 HZ 13 AMP Made in China</p> <p>CONFORME A LA NORMA UL 1090 CERTIFIÉ POUR CAN/CSA STANDARD C22.2 NO. 147-M90</p> <p>SNOW JOE ULTRA MODELO 622U 120 VAC 60 HZ 13 AMP Fabricado en China</p> <p>SNOW JOE ULTRA MODÈLE 622U 120 VCA 60 HZ 13 AMP Fabriqué en Chine</p>
---	---

SJ 622U-2136

Assembly



CAUTION



Inspect wiring, which, if damaged during shipping, may cause serious bodily injury during equipment use. If any damage is seen or suspected, do not assemble. Instead, contact Snow Joe Customer Service for assistance.

Handle with care during assembly so that electrical wiring does not become damaged.

Getting Started

1. Remove the snow thrower and all other items from the box.
2. Determine the left and right hand sides of the snow thrower by standing in the normal operating position.
3. Check all items for shipping damage. If damage is seen or suspected or if any of the parts are missing, do not assemble. Instead, promptly inform the dealer where you bought the snow thrower or contact Snow Joe customer service for assistance.
4. Check to make sure that the parts bag contains all of the following:

Cable clips	(3 pcs)
Upper chute crank	(1 pc)
Two-sided open-end wrench	(1 pc)

Upper, Middle, and Lower Frame Assembly

1. Loosen and remove the four sets of joint fixing T-bolts, washers, and knobs to separate the upper frame from the middle frame (Fig. 2).

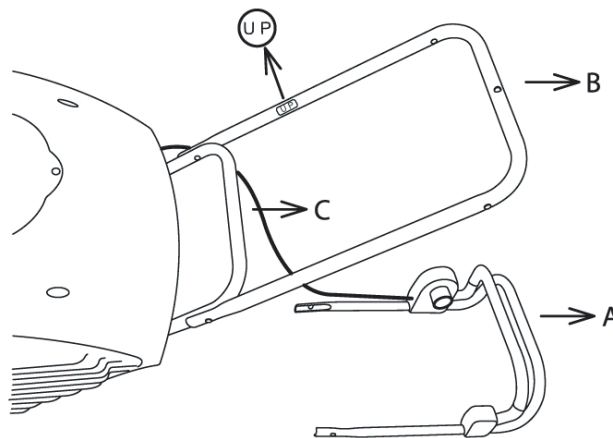

Figure 2

A-Upper frame
B-Middle frame

C-Lower frame

2. Hold the middle frame so that the screw holes align with the holes on the lower frame. Insert the joint fixing T-bolt into the aligned holes on each side. Use the washers and joint fixing knobs to secure the connection on both sides (Figs. 3-5). The joint fixing T-bolts should be inserted inside the frame of the unit so that the washers and joint fixing knobs are fastened to the outside of the frame.

Note:

1. Make sure the middle frame is held upright, following the **UP** mark attached to the middle frame. Holding the middle frame in the reverse direction will not assemble the frames properly.
2. Do not overtighten the joint fixing knobs.

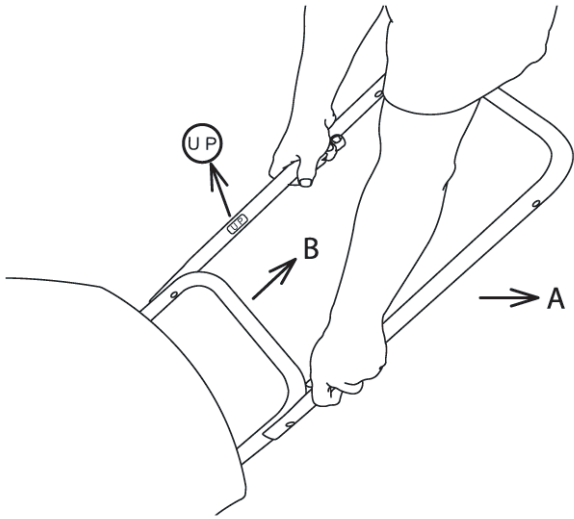

Figure 3

A-Middle frame

B-Lower frame

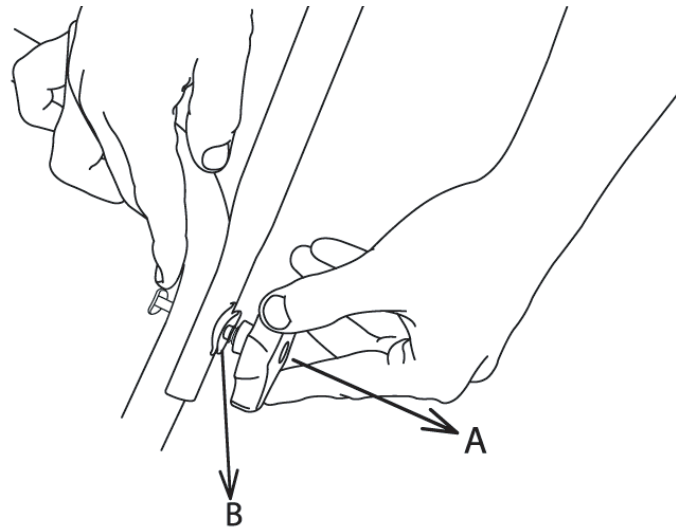

Figure 5

A-Joint fixing knob

B-Washers

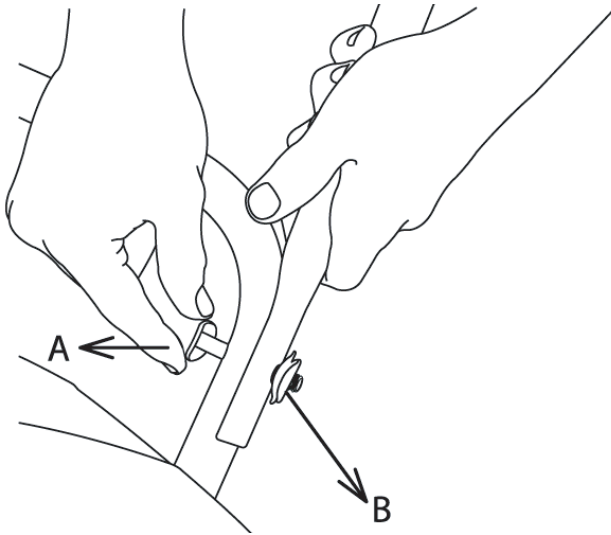

Figure 4

A-Joint fixing T-bolt

B-Washers

3. Connect the upper frame to the middle frame in the same way as described in step 2. Use the joint fixing T-bolts, washers, and knobs to secure the connection on both sides (Figs. 6-8).

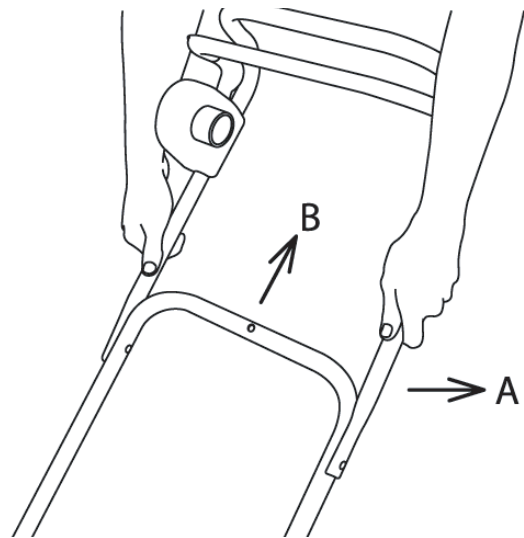

Figure 6

A-Upper frame

B-Middle frame

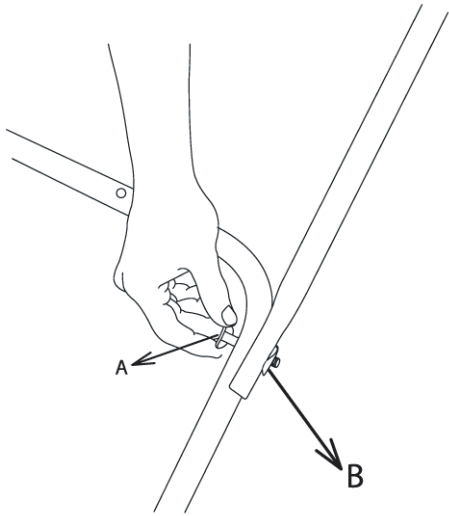

Figure 7

A-Joint fixing T-bolt

B-Washer

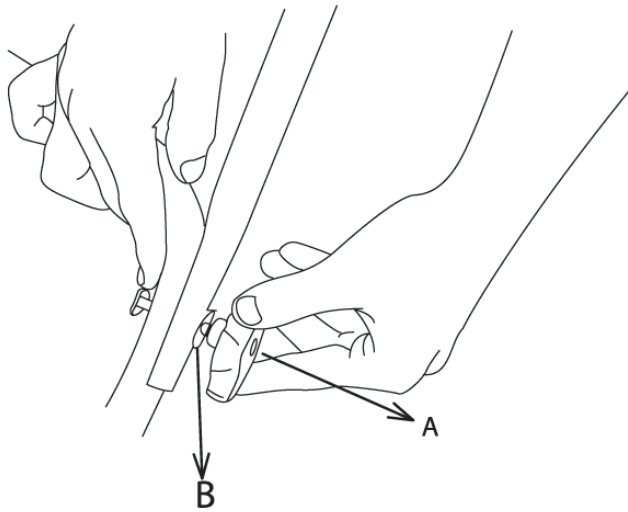

Figure 8

A-Joint fixing knob

B-Washer

4. Locate the three cable clips in the parts bag. Secure the power cord to the frame of the unit by clipping them onto the frame at evenly spaced intervals (Fig. 9).

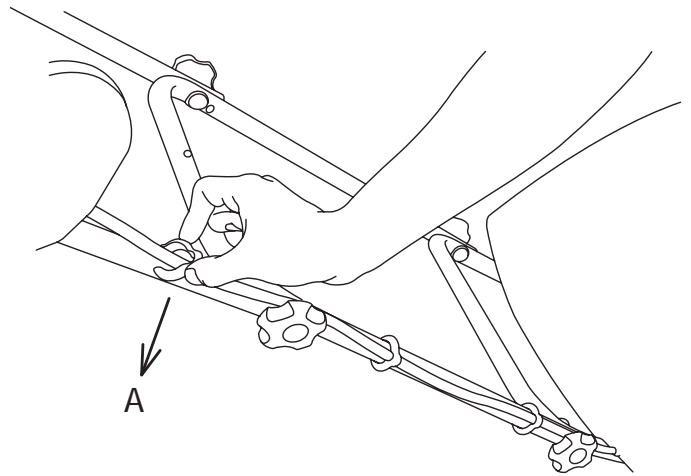

Figure 9

A-Cable clip

Discharge Chute and Chute Crank Assembly

1. Lift the chute deflector so that it snaps and locks securely onto the discharge chute (Figs. 10 and 11).

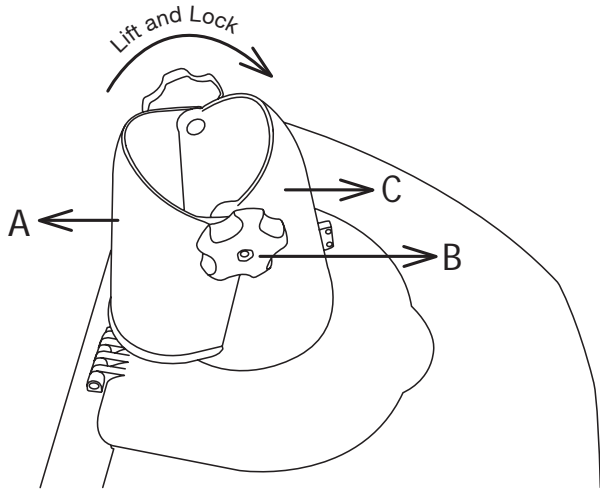

Figure 10

A-Chute deflector C-Discharge chute
 B-Chute deflector knob

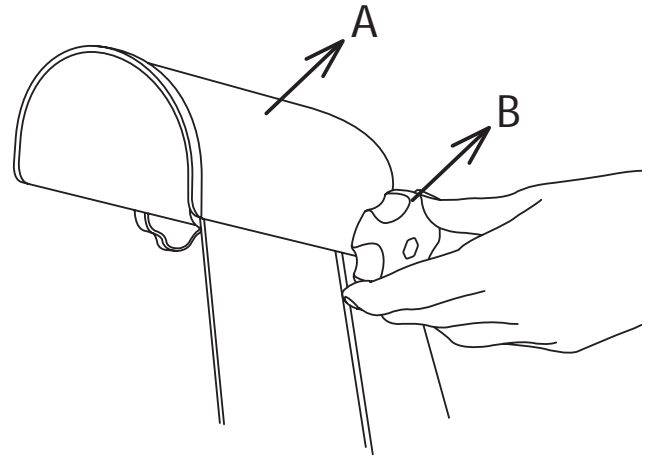

Figure 12

A-Chute deflector B-Chute deflector knob

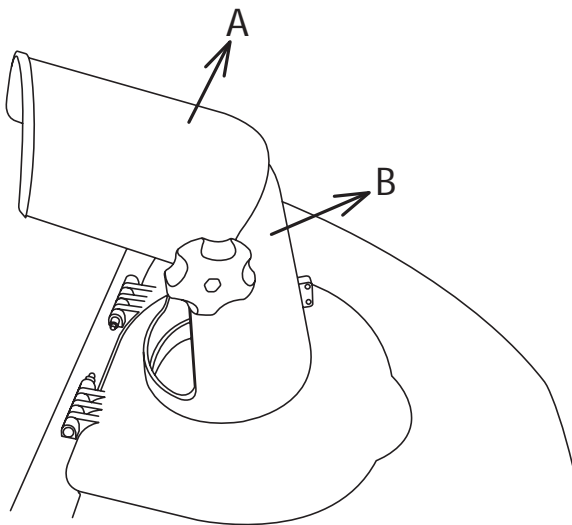

Figure 11

A-Chute deflector B-Discharge chute

2. Raise or lower the chute deflector to the desired height of the snow stream and tighten the chute deflector knobs (Fig. 12).

Note: Do not overtighten the chute deflector knobs.

3. Locate the upper chute crank in the parts bag. Remove the screw and nut from the upper chute crank using a Phillips screwdriver and the wrench provided (Fig. 13).

Note: You may be able to unfasten the screw and nut by hand.

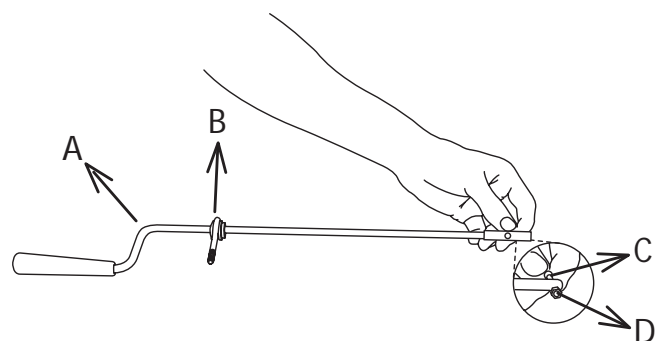

Figure 13

A-Upper chute crank C-Screw
 B-Eye bolt with rubber grommet D-Nut

4. Slide the upper chute crank into the lower chute crank, aligning the screw holes. Tighten the screw into the aligned holes using a screwdriver. Fasten the nut with wrench (Figs. 14 and 15).

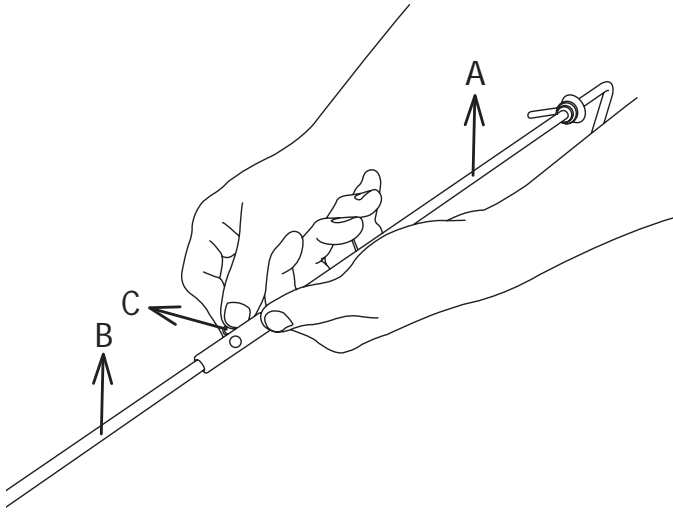

Figure 14

A-Upper chute crank
B-Lower chute crank
C-Screw

5. Remove the washer and nut from the eye bolt with rubber grommet found on the upper chute crank. Position the chute crank so that the eye bolt with rubber grommet inserts into the center hole of the middle frame. Secure with washer and nut (Figs. 16 and 17).

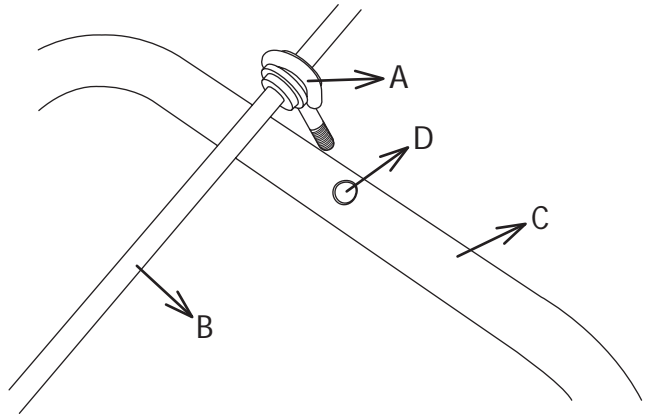

Figure 16

A-Eye bolt with rubber grommet
B-Upper chute crank
C-Middle frame
D-Center hole

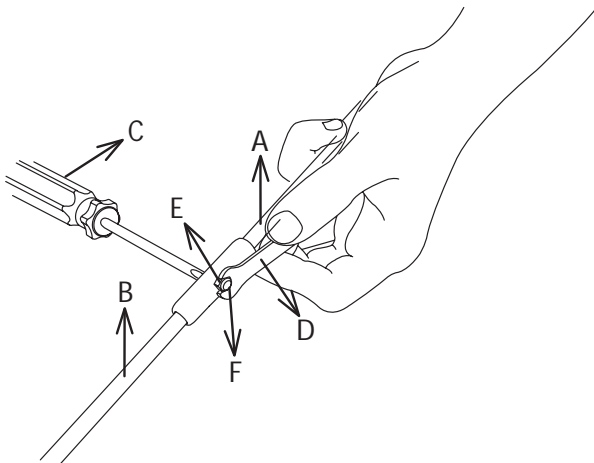

Figure 15

A-Upper chute crank
B-Lower chute crank
C-Screwdriver
D-Wrench
E-Nut
F-Screw

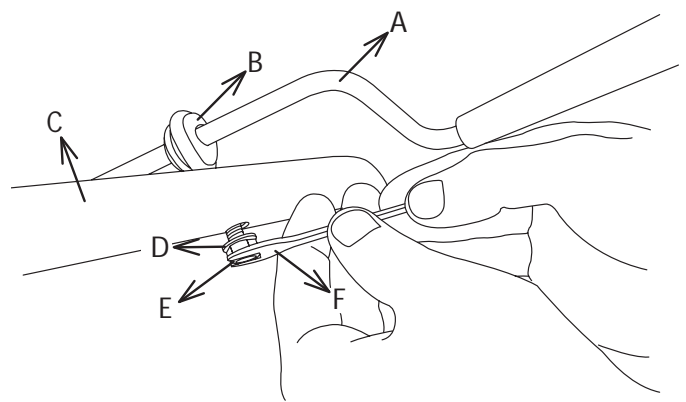

Figure 17

A-Upper chute crank
B-Eye bolt with rubber grommet
C-Middle frame
D-Washer
E-Nut
F-Wrench

Operation

Note: Before using this machine, make sure that the power source you will use complies with the specifications detailed in this manual. Before inserting the plug into the socket, verify that the snow thrower's roll shaft and rubber plates are firmly secured with screws, and that the rubber plates are facing the correct direction. Perform a test run to ensure that the rotor turns freely.

Securing the Extension Cord

1. For safe and efficient use of your snow thrower, use only a UL-rated extension cord recommended for outdoor use. Refer to the Extension Cord Chart that follows.

⚠ **WARNING** ⚠

Electric shock may cause SEVERE INJURY or DEATH. Heed these warnings:

- Do not allow any part of snow thrower to make contact with water while powered on. If the appliance becomes wet while turned off, wipe dry before starting.
- Use only a UL-rated extension cord for outdoor, all-weather use. Do not use an extension cord over 150 feet (46 meters).
- Do not touch the appliance or its plug with wet hands or while standing in water. Wearing rubber boots offers some protection.

EXTENSION CORD CHART		
Cord length is:	100 ft. (30 m)	150 ft. (46m)
Wire gauge is:	16	14

2. To prevent the extension cord from disconnecting during use, tie the female end of the extension cord into a loose knot on the top right side of the middle frame before connecting to the male plug in the switch housing socket of the snow thrower (Fig. 18).

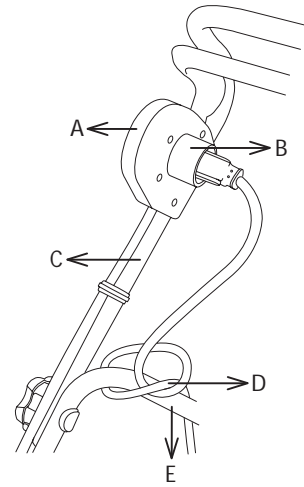

Figure 18

- A-Switch housing
- B-Polarized plug
- C-Upper frame
- D-Cord tied to middle frame
- E-Middle frame

3. Note that the snow thrower has a polarized male plug, with one prong in the switch housing socket slightly longer and wider than the other (Fig. 19). The extension cord female end should be likewise polarized, so that the extension cord fits snugly into the switch housing socket.

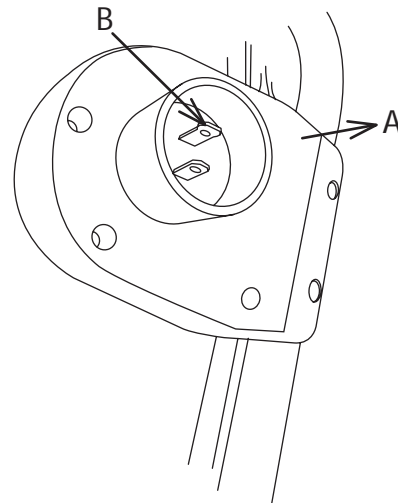

Figure 19

- A-Switch housing
- B-Polarized plug



WARNING



Damaged electrical cords present risk of fire, electrical shock, and serious bodily injury.

Before operating the snow thrower, carefully examine the electrical cord. If the cord is damaged, do not use the snow thrower. Replace or repair the damaged cord immediately. If you need assistance, contact an authorized Snow Joe dealer.

Powering On and Off

1. To power on, first press the switch button found alongside the switch housing (Fig. 20).

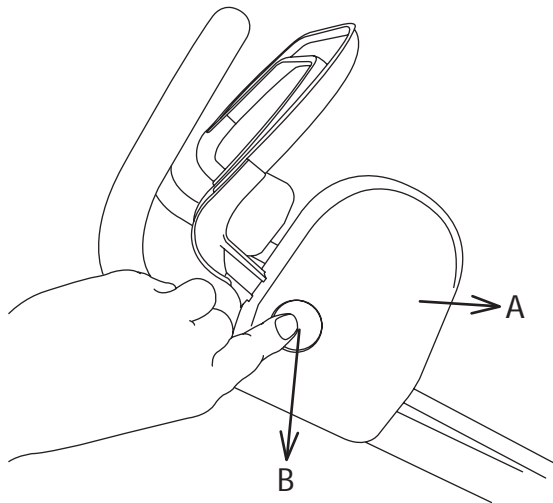

Figure 20

A-Switch housing

B-Push button switch

2. Pull the handle bar toward you and grasp hold of it firmly with both hands to start the machine (Fig. 21). The machine can only be started by pressing the switch button first, followed by squeezing the handle bar. Reverse operation cannot start the machine.

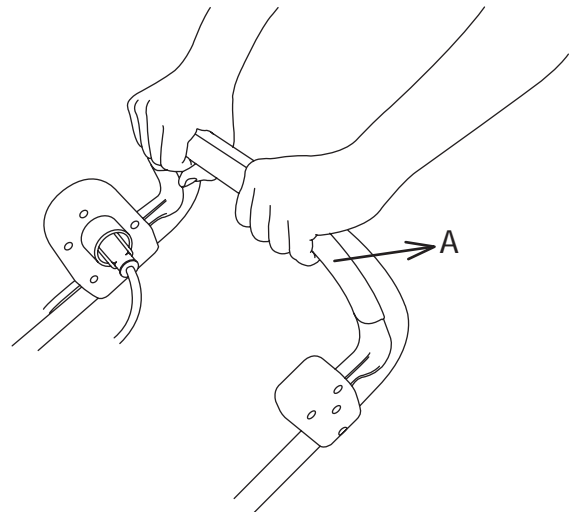

Figure 21

A-Handle bar

3. To power off, release your grip on the handle bar.

Moving the Machine and Plowing the Snow



WARNING



Foreign objects, such as rocks, broken glass, nails, wire, or string, can be picked up and thrown by the snow thrower, causing serious personal injury.

Remove all foreign objects from the area to be plowed before operating the snow thrower.

1. Keep the area of operation free of foreign objects that can become thrown by the rotor blades. Perform a thorough inspection of the area since some objects may be hidden from view by surrounding snow. If the snow thrower hits an obstruction or picks up a foreign object during use, stop the snow thrower, disconnect the extension cord, remove the obstruction, and inspect the unit for damage. Repair or replace any damaged part before restarting and operating the unit.
2. Keep children, pets, and bystanders away from the area of operation. Be aware that the normal noise of the machine when turned on may make it difficult for you to hear approaching people.
3. When moving the snow thrower, use the wheels on one side as the pivot point. Slightly tilt the snow thrower on this pivot point to move it forward or backward.
4. Start your clearing path near the electrical outlet and work outward, throwing snow in a back and forth motion. To clear in the opposite direction, step over the cord and pivot the snow thrower on its wheels. Make sure to overlap clearing paths.
5. Note wind direction. If possible, move in the same direction as the wind so that the snow is not thrown against the wind (and thus back into your face and on the just cleared path).
6. While moving the snow thrower, do not drag the power cable violently or roughly. The snow thrower should move within the range that the cable can reach.
7. Do not push the snow thrower with excessive force. You should push the machine gently and evenly in accordance with the unit's throw rate.
8. Do not apply additional man-made load to the engine since this may cause engine damage.
9. Some parts of the snow thrower may freeze under extreme temperature conditions. Do not attempt to operate the snow thrower with frozen parts. If the parts freeze while the

snow thrower is in use, stop the snow thrower, unplug the extension cord, and inspect for frozen parts. Free all parts before restarting or operating the snow thrower. Never force controls that have frozen.

10. Working on pebbles, gravel, or unpaved surfaces - To avoid throwing loose surface material along with the snow, push down on the handle to raise the scraper at the base of the unit above the pebbles or gravel.

Changing Throw Direction and Throw Height



WARNING



Never direct the snow discharge chute at the operator, at bystanders, at vehicles or at nearby windows. The discharged snow and foreign objects accidentally picked up by the snow thrower can cause serious damage and personal injury.

Always orient the discharge chute in the opposite direction from where you, bystanders, surrounding vehicles, or windows are located.

1. The discharge chute can be adjusted 180 degrees by rotating the chute crank. Rotate the chute control crank clockwise to move the discharge chute to the left (Fig. 22); counterclockwise to move the chute to the right (Fig. 23).

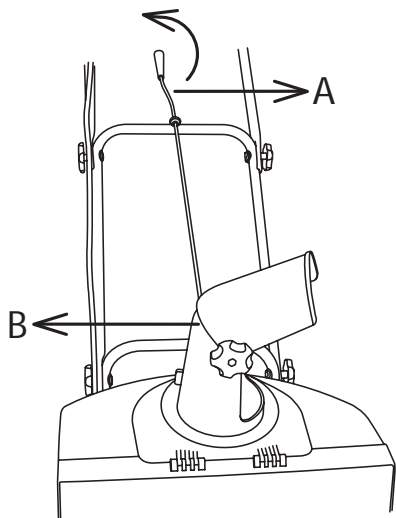

Figure 22

A-Chute crank

B-Discharge chute

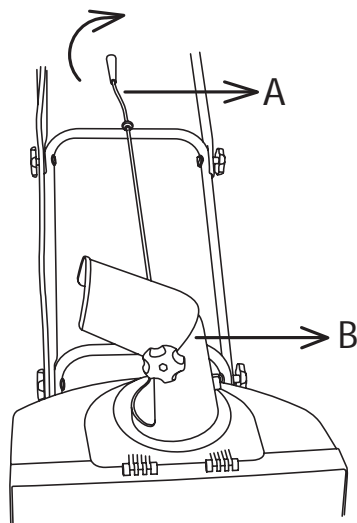

Figure 23

A-Chute crank

B-Discharge chute

- The chute deflector on the top of the discharge chute controls the height of the snow stream. Loosen both chute deflector knobs to raise or lower the deflector to the desired height of snow you wish to throw. Tighten the knobs to secure the deflector (Fig. 24).

Note: Do not overtighten the chute deflector knobs.

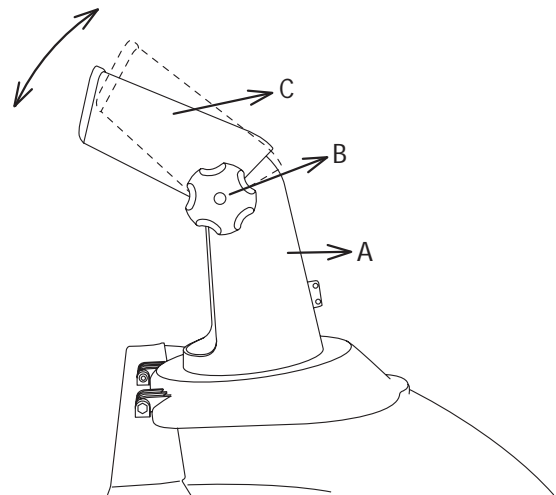

Figure 24

A-Discharge chute

B-Chute deflector knob

C-Chute deflector



WARNING



Make sure that the chute deflector snaps and locks completely onto the discharge chute. An opening between the discharge chute and the chute deflector may allow foreign objects to be picked up by the snow thrower and thrown in the direction of the operator causing serious boldly injury.

- Do not advance the chute deflector too far forward causing an opening to appear between the deflector and discharge chute.
- Do not overtighten the knobs on the chute deflector (Fig. 12).

Maintenance

⚠
WARNING
⚠

Make sure to turn off the switch and disconnect the extension cord before performing any maintenance task on your snow thrower.

Lifetime Lubrication

Lubrication is not necessary and may damage the unit. The snow thrower is lubricated for lifetime use at the factory before shipment.

General Maintenance Tips

1. Do not attempt to repair the machine unless you have the proper tools and instructions for disassembly and repair of the machine.
2. Check the shear bolts and other bolts at frequent intervals for proper tightness to ensure that the equipment is in safe working condition.
3. After each snow removal session, run the snow thrower for a few minutes to prevent the collector/impeller from freezing. Shut off the motor, wait for all revolving parts to stop completely, and wipe residual ice and snow off the unit. Rotate the chute crank several times to remove any excess snow.

Replacing the Rubber Plates

Note: When replacing worn rubber plates, pay close attention to carefully distinguish between the coarse and smooth side of the plates. Place the coarse side inside and the smooth side outside.

1. Detach the worn rubber plate by removing the two sets of nuts, bolts, and washers used to secure it.
2. Install the new rubber plate so that the coarse side faces inward and the smooth side faces outward (Figs. 25-27).
3. Insert the bolt with the small flat washer into the corresponding holes on each end of the rubber plate. Use the large flat washer and locknut to secure the bolt on each end. Install the other rubber plates in the same way (Figs. 25-27).

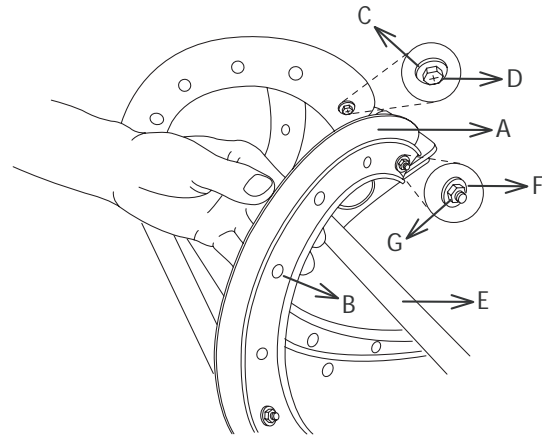

Figure 25

- | | |
|---------------------|---------------------|
| A-Rubber plate | E-Auger |
| B-Rivet | F-Large flat washer |
| C-Small flat washer | G-Locknut |
| D-Bolt | |

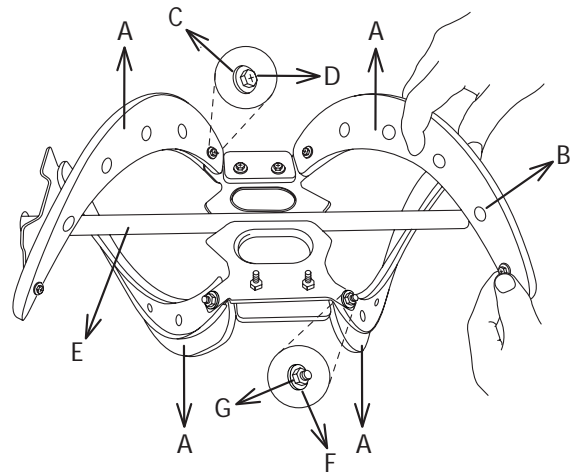

Figure 26

- | | |
|---------------------|---------------------|
| A-Rubber plate | E-Auger |
| B-Rivet | F-Large flat washer |
| C-Small flat washer | G-Locknut |
| D-Bolt | |

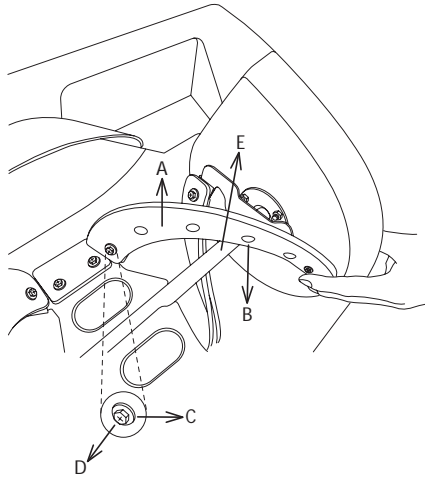

Figure 27

- | | |
|---------------------|---------|
| A-Rubber plate | D-Bolt |
| B-Rivet | E-Auger |
| C-Small flat washer | |

Replacing the Scraper

The scraper is located at the base of the snow thrower beneath the rotor housing (Fig. 28).

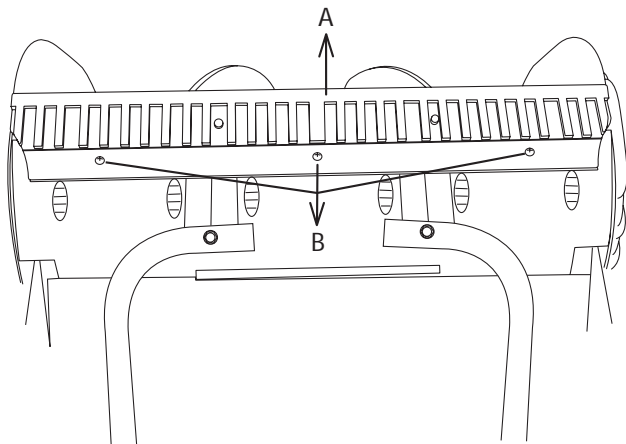

Figure 28

- | | |
|-----------|---------|
| A-Scraper | B-Screw |
|-----------|---------|

1. Detach the worn scraper from the snow thrower by removing the 3 screws that hold it in place (Fig. 29).

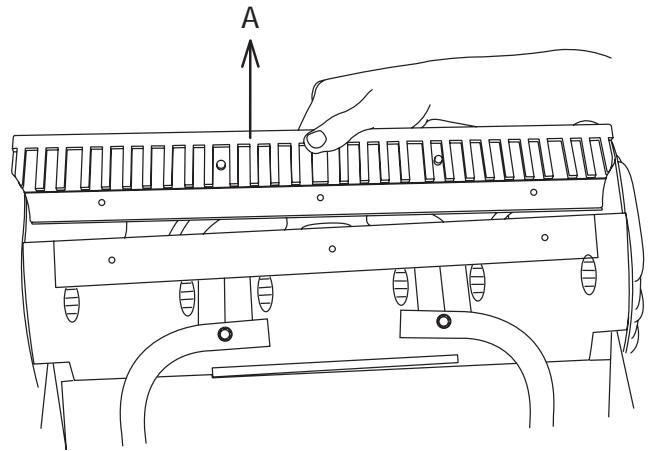

Figure 29

A-Scraper removal

2. Install the new scraper and fasten it securely to the snow thrower with 3 screws (Fig. 30).

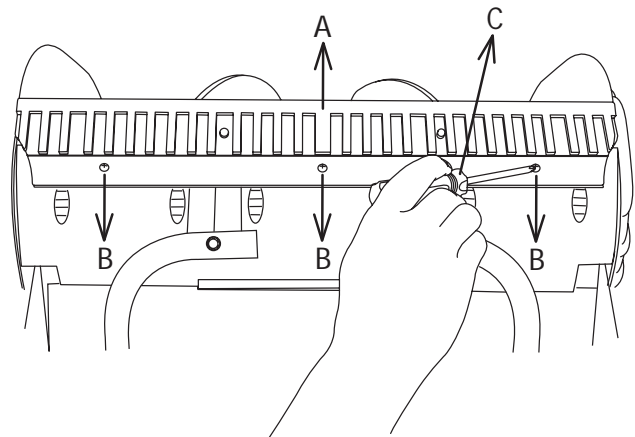

Figure 30

- | | |
|-----------|---------------|
| A-Scraper | C-Screwdriver |
| B-Screw | |



**A Two-Year Full Warranty
for residential use
in the United States and Canada**

General Conditions: Snow Joe, LLC warrants this product to the original purchaser for two years against defects in material or workmanship when used for normal residential purposes. In order to obtain a replacement unit or repair the existing unit, you must return the complete unit, postage prepaid, to the place of purchase, or to the Snow Joe Center, (61 Executive Avenue, Edison, NJ 08817).

This warranty is intended to cover product defects only. Snow Joe, LLC is not liable for indirect, incidental or consequential damages in connection with the use of the Snow Joe Products covered by this warranty. This warranty does not cover any cost or expense incurred by the purchaser in providing substitute equipment or service during reasonable periods of malfunction or non-use of this product, while waiting for completion of repairs under this warranty. Some states do not allow exclusions of incidental or consequential damages, so the above exclusions may not apply in all states. This warranty gives you specific legal rights in your state, which vary from state to state.

If you wish to contact Snow Joe®, please direct inquiries to the:
Customer Service Department
Snow Joe Center
61 Executive Avenue
Edison, NJ 08817

Customers who have purchased Snow Joe products exported from the United States and Canada should contact their Snow Joe Distributor (Dealer) to obtain information applicable for your country, province, or state. If for any reason, you are not satisfied with the distributor's service, or if you have difficulty obtaining warranty information, contact your Snow Joe importer. If in the event your efforts are unsatisfactory, please write to the Snow Joe Center at the above address.